

# **KEMEX™** **DOSING SYSTEMS**

---

 **Akamex**  
INDUTRADE GROUP

## Company profile



### Business idea

The business objective of Akamex Oy is to improve the productivity by minimizing losses, production breaks and quality variations caused by dosing.

### Core functions

- KEMEX™ precision doser manufacturing
- Application design of the dosing systems
- Start-up supervision and training
- Maintenance services

### Background

Akamex Oy has been based in the Jyväskylä region since 1987, and has operated within the Indurade trading group since 1999. Together with its sister companies operating in Finland; Akamex Oy offers a comprehensive range of solutions for liquids handling requirements of the process industry.



### KEMEX™ application design key features:

#### ACCURACY

The dosing system must have a good absolute accuracy and repeatability without calibration

#### RELIABILITY

The availability of the system should be higher than the entire process

#### FLEXIBILITY

The system should be compatible with the digital control system and meet all drive conditions

#### SIMPLICITY

A simple construction saves room and is easy to maintain

#### CLOSED CONSTRUCTION

Liquid handling must be closed and should not have any intermediate stages

Akamex Oy  
P.O.Box 20  
FIN-40251 JYVÄSKYLÄ, Finland  
Tel. +358 14 3334 000  
Fax +358 14 3334 044  
akamex.info@akamex.fi  
www.akamex.fi

# Kemex™ doser

The KEMEX™ doser is an ideal solution for all batch-typed dosing in which accuracy, reliability, chemical resistance and flexible control are required. Typical applications for the KEMEX™ doser include all batch-type dosing processes that incorporate dosages based, for example, on weighing or volume flow, which are upgradeable with KEMEX™ technology.

In processes involving several base components KEMEX™ dosers can be used in parallel to reduce thorough-put time and boost total capacity. In addition, the KEMEX™ doser is well suited to continuous processes, which have long enough delays to level off the doser's pulsating output

## Key features of the KEMEX™ doser

- Pneumatically operated valves control the dosing sequence, with the flow of the liquid being dosed actually moving the dosing piston.
- Doser cannot run dry. A built-in end-of-stroke alarm alerts operators, if the dosing process is interrupted for any reason.
- Viscosity and dosing volume do not affect accuracy or repeatability of the dosing process.
- A simple and reliable design allows a long system operating life with virtually no maintenance. The design is also explosion-proof. Materials used in the construction are designed for the harsh operating environment and the corrosive nature of chemicals.

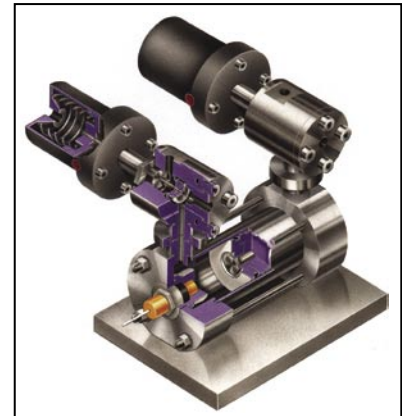

## TECHNICAL SPECIFICATIONS

STROKE VOLUME	1.0 – 2000.0 ml/stroke
MATERIALS	
Metal structure	AISI316L/PP/PVDF/C-PTFE
Plastic structure	PVDF/PP/C-PTFE
TEMPERATURE RANGE	0 – 60 °C
PRESSURE RAITING	PN10/PN16

**CONTROL INTERFACES**  
 Limit switches 24VDC, 120/240VAC  
 Instrument air 0.5 – 0.8 Mpa

**PROCESS CONNECTORS**  
 N20 – N63 R1/2" female thread  
 N80 R3/4" female thread  
 N125 R1" female thread

Flange connectors upon request

### KEMEX™-dosers:

KEMEX™ N20	1.0 - 5.0 ml/stroke	max. 30 strokes/min
KEMEX™ N32	5.0 - 50.0 ml/stroke	max. 30 strokes/min
KEMEX™ N63	50.0 - 250.0 ml/stroke	max. 30 strokes/min
KEMEX™ N80	250.0 - 1000.0 ml/stroke	max. 25 strokes/min
KEMEX™ N125	1000.0 - 2000.0 ml/stroke	max. 20 strokes/min

### Typecode

**N80 - 1000.0 - 2M**

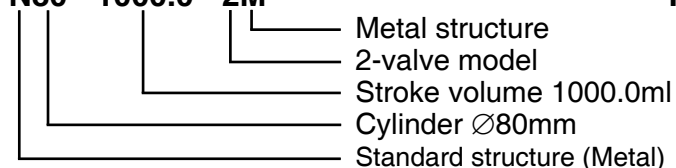

**P32 - 50.0 - 4P**

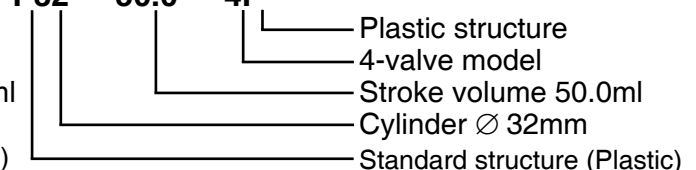

N.B.! 2-valve model only possible for >100ml stroke volumes

## KEMEX™ dye dilution system



Dyes are used in papermaking to give the end product an alternative color or add certain tint to standard white paper. The use of colors changes the dominant wavelength and color purity of the paper. They are also used to influence opacity, and to compensate for variations in raw materials in order to standardize the visual quality of the end product.

The KEMEX™ dye dilution system, complete with feeding pump and flow control system, forms a whole system designed for the tinting and coloring of all paper grades.

The system is based on the KEMEX™ dilution system, providing precise dosage measurement and preparation of solution to desired concentration. The mixture is prepared in mixing tank (V=1100L), which also function as storage tank. The uniform quality of the diluted dye is controlled by dosing concentrated dye and water into a static pre-mixing vessel inside the tank, from which the diluted dye is conducted along an overflow pipe into the tank.

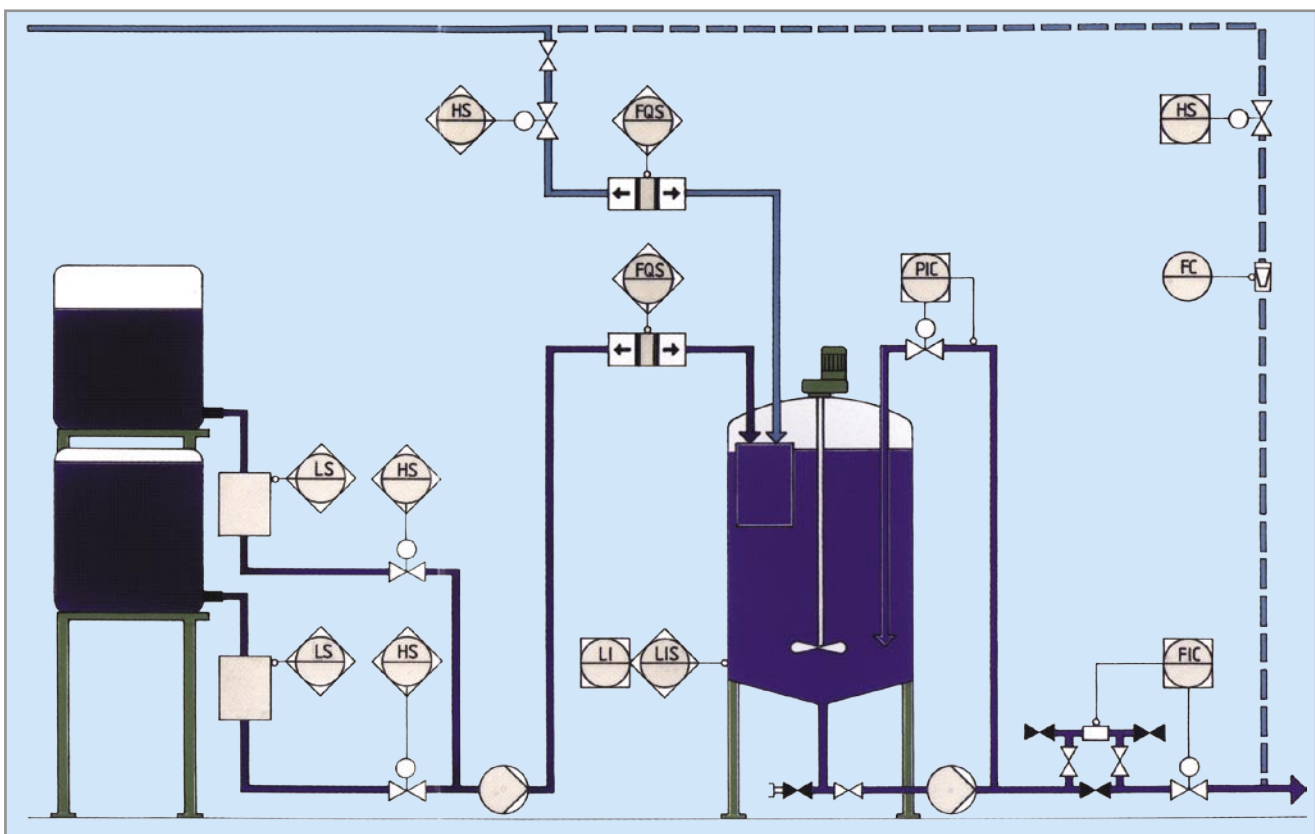

The KEMEX™ dye dilution system

# Coating color kitchen chemical and additive dosing system

The high accuracy of the KEMEX™ doser and its calibration-free, viscosity independent repeatability features are perfectly suited to the liquid additive and chemical dosage requirements of coating color manufacture.

The system below, features two identically dye dosing systems for two different dyes. The amount of dye is precisely measured by the KEMEX™ dosers, the stroke volume typically ranging between 5.0 – 50.0ml. The exact dye quantity measured by the KEMEX™ dosers is dosed concentrated into the coating color mixer.

KEMEX™ dye dosing systems comprise the following main components:

- Dye storage tank, delivery container or storage tank
- AKASENS container empty sensor
- Pressurizing pump, air operated diaphragm pump
- The KEMEX™ doser
- Recycling valve

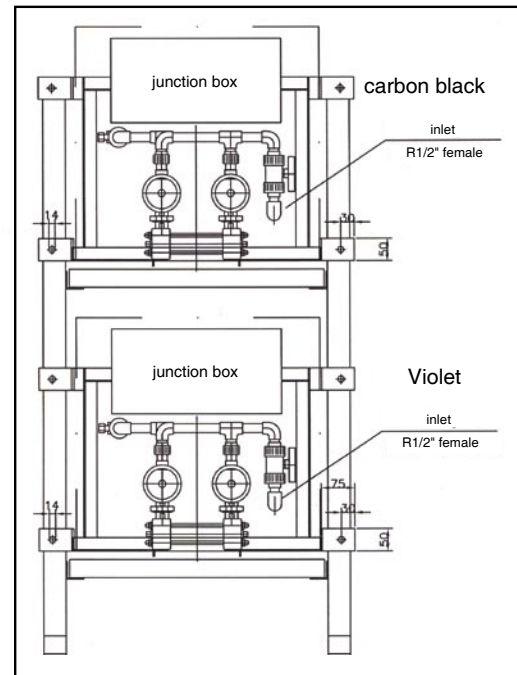

The container rack with its equipment is positioned in a location, which is easily accessible, by forklift truck, and the KEMEX™ dosers and recycling valves are located in close proximity to the coating color mixer. During the preliminary dosing sequence the dye is recycled back into the container for a brief period in order to evacuate unwanted sedimentary deposits from the pipe system.

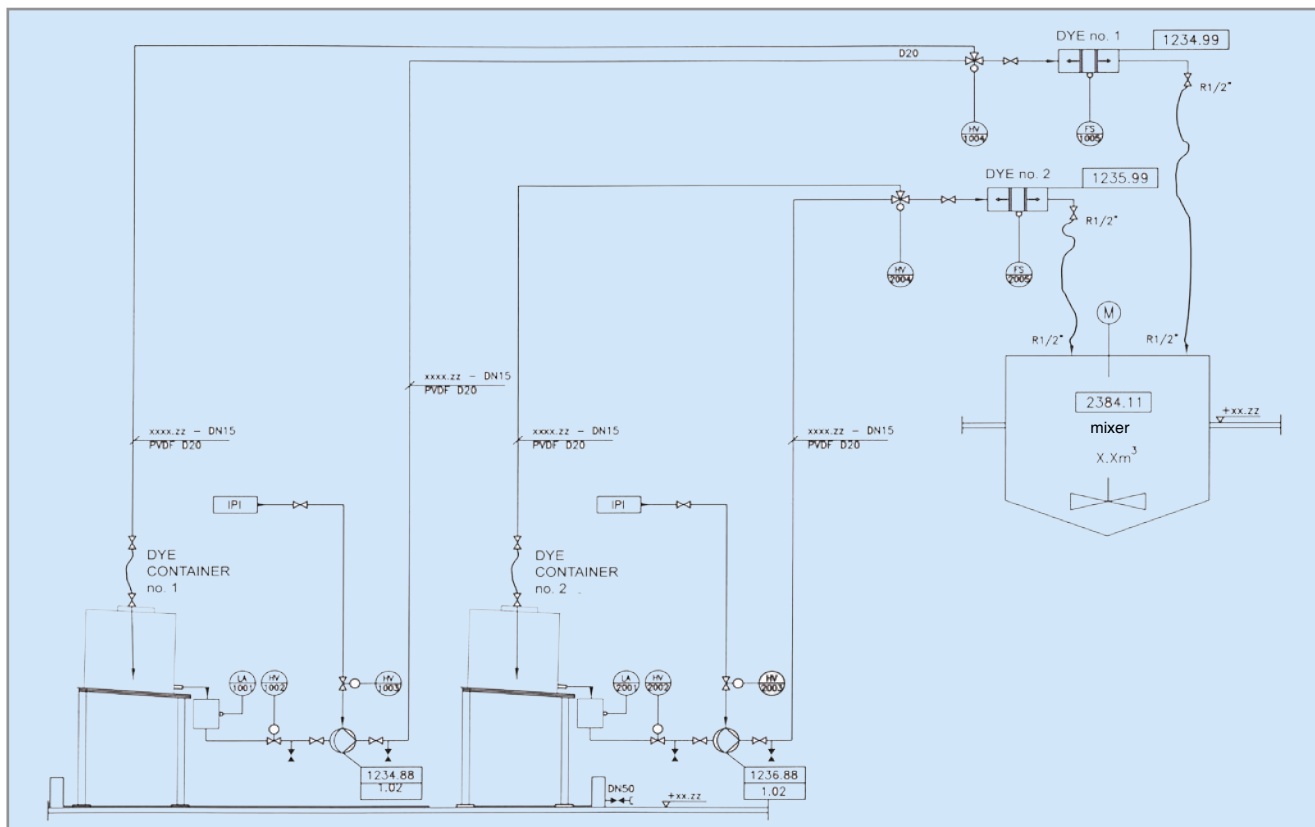

The KEMEX™ coating color kitchen dye dosing system

# KEMEX™ Biocide dosing system



The KEMEX™ biocide dosing system consist of one to four KEMEX™ dosers, each of which able to supply up to six targets (on the dosing line). Each line is equipped with counting function. Line target selection is determined by the line selection valves. Only one of these valves can be open at the same time. If the dosing is activated to several lines simultaneously, the control unit distributes the doser supply evenly between each of the six lines.

The KEMEX™ biocide dosing system, as illustrated below, is equipped with a double contained system, which enables automatic container change-over during container emptying. Storage tanks manufactured from PEHD plastic provide an additional biocide storage alternative.

Dosing recipes determine how the biocide is dispensed to each line. Each line has its own dosing recipe to which a total of ten different dosing events can be entered. Three dosing method options are available: real-time based dosing, continuous dosing controllable via external signal and single-batch.

The KEMEX™ biocide dosing system is linked to a higher-level automation system (DCS) through binary signals (line-specific dosing control and alarm data) or via PROFIBUS fieldbus technology.

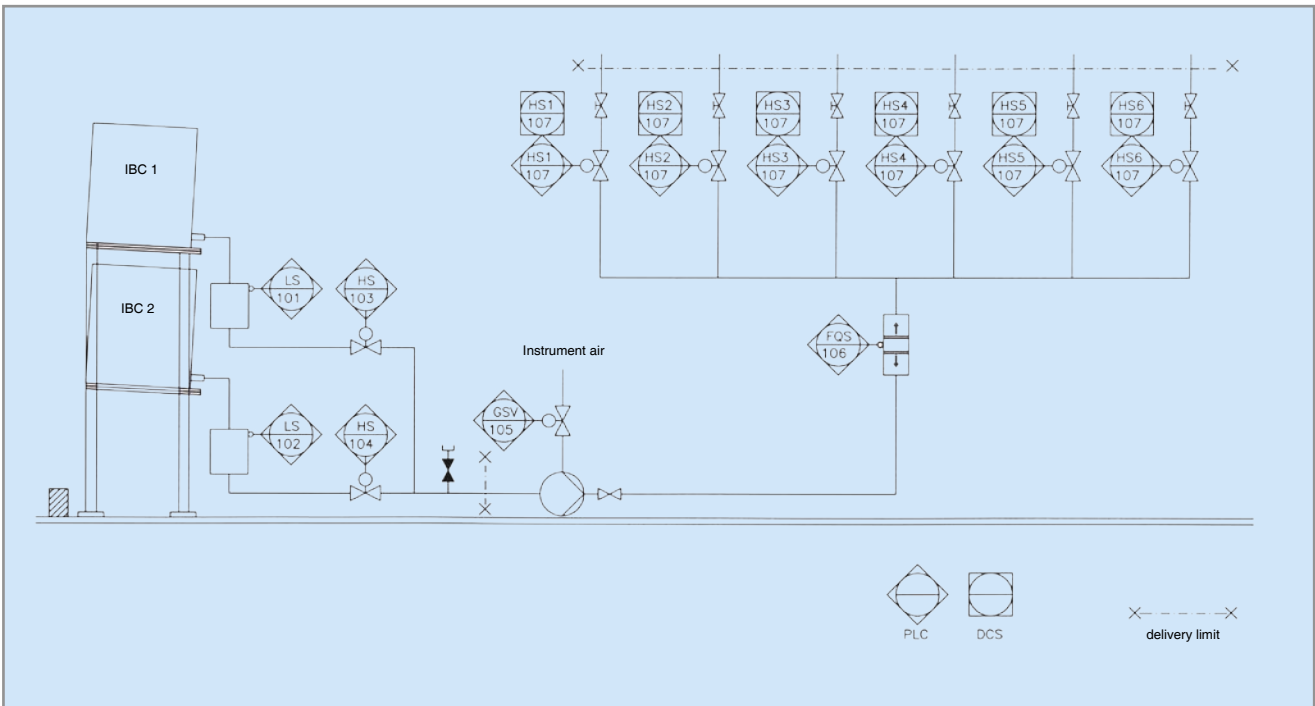

The KEMEX™ biocide dosing system

# Handling and storage of chemicals and additives

## Container hoses

The container hoses consists of flexible wire-cloth braided PTFE with KAMLOK connectors.

The hose structure has been specifically designed for both leak-proof and ease of use.



## Container racks

Connecting two containers in parallel using AKASENS container empty sensors to switch from the emptied container to the full one can ensure continuous dosing directly from the delivery containers. Alternatively chemicals can be stored in fixed plastic tanks in which chemical is fed by gravity from delivery containers mounted above fixed tanks.

The storage tanks can be equipped with level monitoring and agitator.

## Container empty sensors

The AKASENS container empty sensor ensures complete container draining and keeps line full. In the double container system the sensors together with change-over valves ensures continuous production and provides remote alarm on empty container.

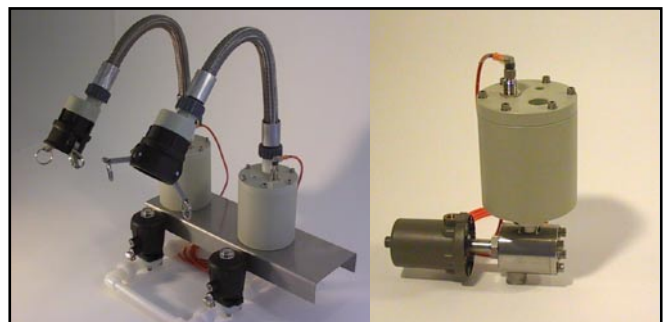

## Mixing tanks

Mixing tanks are designed to also function as storage tanks. Dosing chemical and dilution water into the static pre-mixing vessel inside the tank controls uniform quality of the diluted chemical. The enclosed combination tank is usually sized at a small volume (1.1m<sup>3</sup>). This design allows optimal installation of the KEMEX™ dilution system in areas with restricted installation space. The tank is equipped with level monitoring, continuous agitation and a manhole on the top of the tank.

All wetted KEMEX™ dosing system components are made of chemical corrosion resistant material.

# Dosing system service package

**KEMEX™ precision doser manufacture and dosing system installation**

**Application design and documentation of dosing systems**

- Mechanical and automation engineering
- Software engineering
- Process engineering

**System start-up and training**

**Maintenance and spare part services**

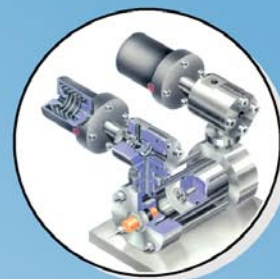
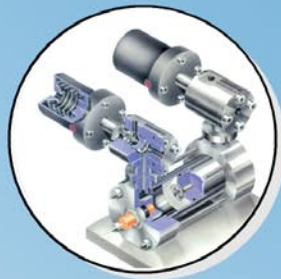
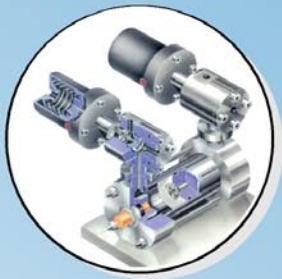

 **Akamex**  
INDUTRADE GROUP

P.O.Box 20 FIN-40251 JYVÄSKYLÄ, Finland  
Tel. +358 14 3334 000, Fax +358 14 3334 044  
[www.akamex.fi](http://www.akamex.fi), [akamex.info@akamex.fi](mailto:akamex.info@akamex.fi)